

**Pelleting Equipment**

**Bulletin 5040**

Revised 1/78

**Sprout-Waldron**

**Model 26-300  
Pellet Mill**

**KOPPERS**

Engineered  
Products

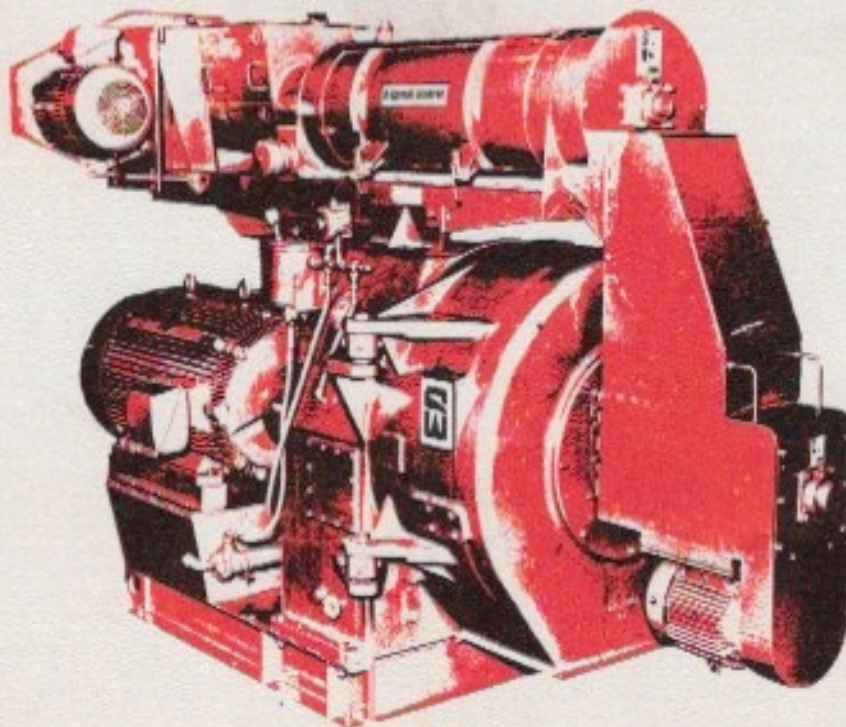

# Sprout-Waldron Model 26-300 Series Pellet Mill

**...the pellet mill  
that offers  
substantially  
more for the  
dollar invested!**

## **no other pellet mill offers all these features**

- Dual or Single Speed Operation.
- Rapid-Change Pelleting Cartridge.
- Largest Die in Industry.
- Unmatched Feed Distribution.
- Three 10" Rolls.
- Simplified Design for Reduced Downtime, Lower Maintenance Cost.

The Sprout-Waldron 26-300 series of pellet mills offers a wide selection of designs including (1) single and (2) dual speed drives, use of (3) wide or (4) narrow dies . . . or a combination (5) of both wide and narrow in a single mill. This versatility combines with the many unique features of the 26-300 to help the modern miller meet the challenge of: least-cost formulation, production of both cubes and small pellets, short runs, frequent die changes and high quality demands from his customers.

These features mean higher tonnages per man/hour, longer die and roll life and lower maintenance costs.

The following pages of this bulletin will detail the features that make this performance possible.

The 26-300 series is the feed man's answer to the need to cut costs with higher capacities, more efficient operation, increased production capacity per square foot of floor space, lower power consumption and reduced main-

tenance costs.

Sprout-Waldron's design philosophy has always been to provide dependability so its machines perform as well after years of productive use as when they were new. The 26-300 series meets the test . . . giving you a rugged, precision-built machine that results in the lowest cost per ton of feed produced! And, testimonials from Sprout-Waldron pellet mill owners verify the claim of *substantially* lower operating and maintenance costs.

We've found that "expert" operators can make *anybody's* pellet mill do production wonders . . . they just have a "feel" for coaxing the most from a machine without plugging it.

But . . . what about the *average* operator's performance?

The 26-300 series has built-in features to permit the *average* operator to produce like an *expert*. That's important to your profits!

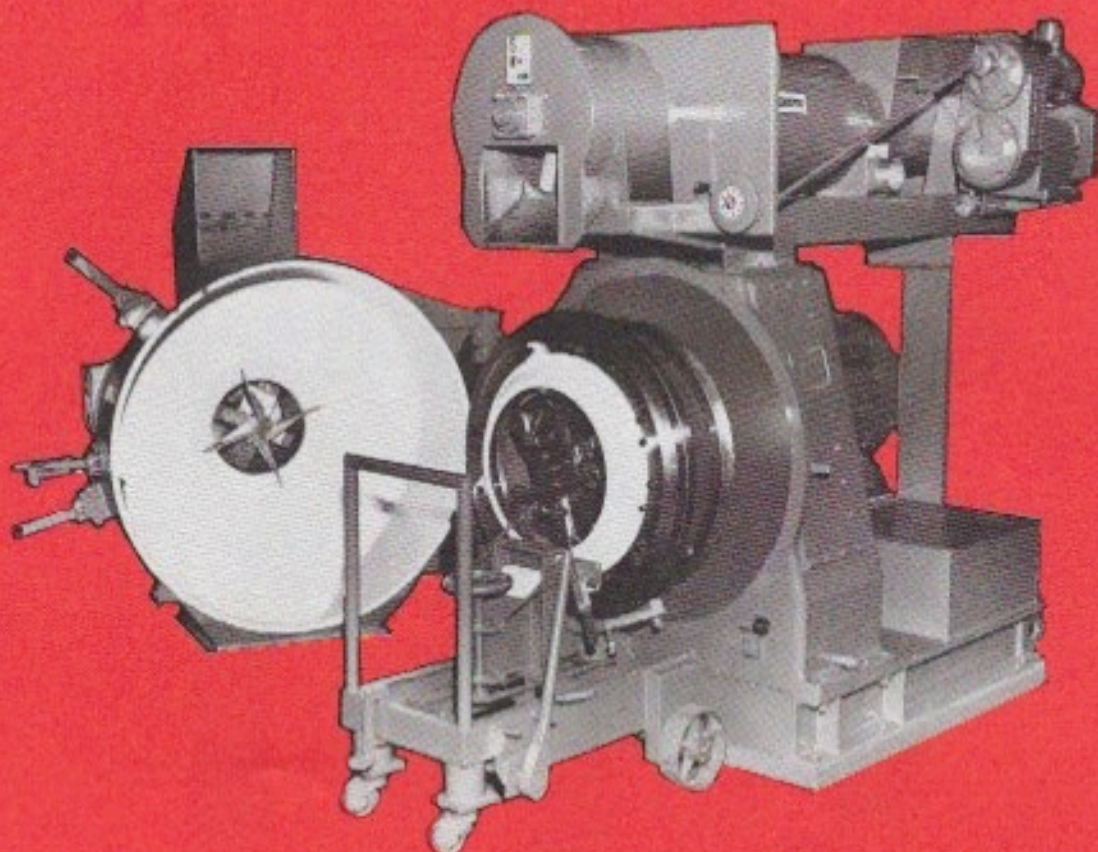

*This single speed version Model 26-300 pellet mill features quick change cartridge and transport cart.*

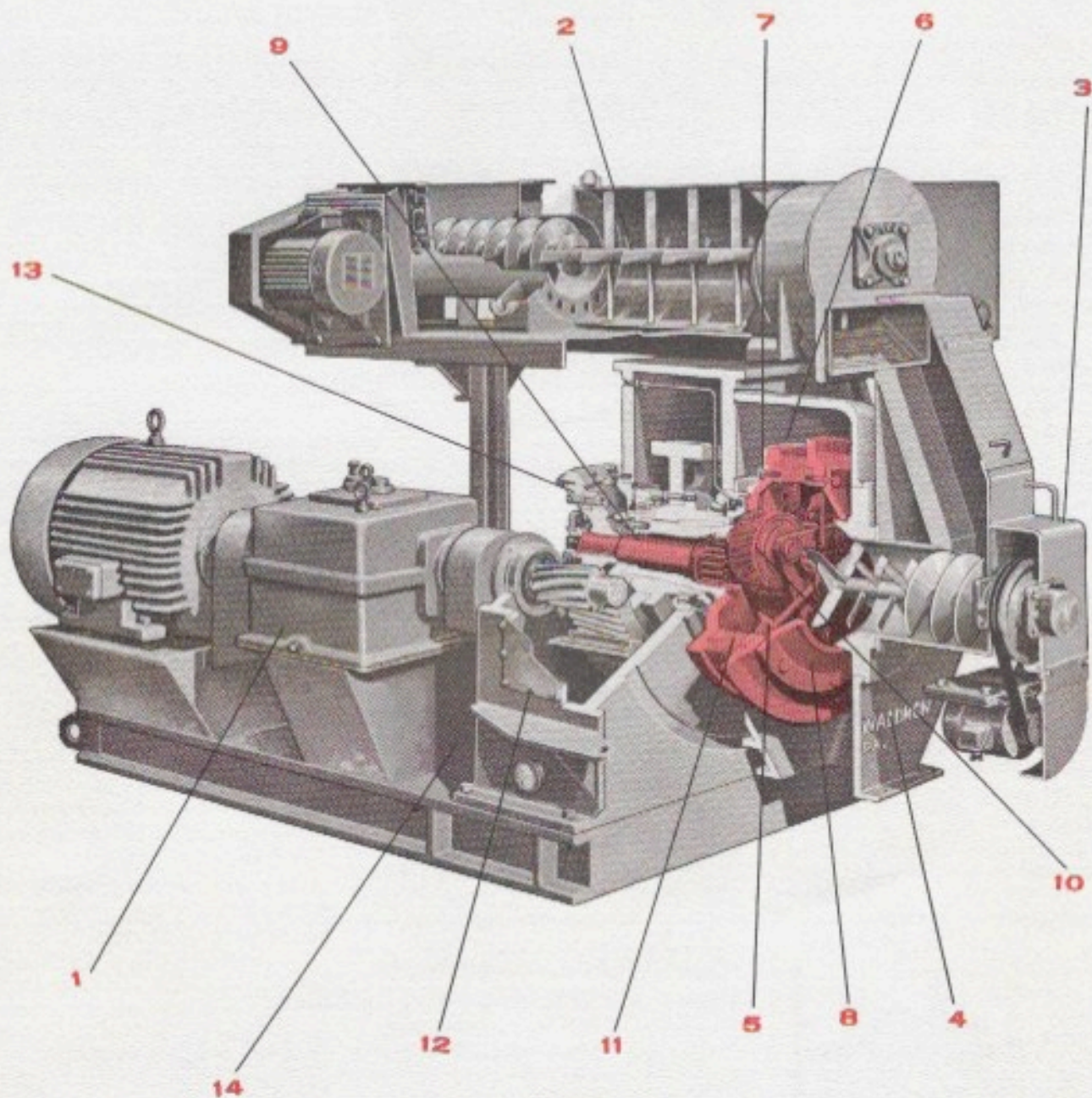

1. Transmission for Dual Speed Model. (Omitted for single-speed model).
2. In-line Feeder-Conditioner
3. Centri-feeder<sup>®</sup> Distributor
4. Hinged Die Casing
5. Adjustable Feed Plow (3)

6. Die
7. Die Holding Bolt
8. Die Stiffener Ring
9. Heavy Duty Main Shaft
10. Roll Assembly (3)

11. Rapid-Change Pelleting Cartridge (All parts shaded in red)
12. Gear Casing
13. Shear Pin Protection
14. Positive Lubrication (Location only; system components not shown)

## The Critical Feeding Question

Undoubtedly one of the most essential factors in producing quality pellets at high capacity is a uniform mat of mash across the *full face* of the die and proper feedrate to each roll.

Competitive designs depend largely on chance to move material from the feed chute around the rolls and into the die cavity.

To provide this critical feed distribution, Sprout-Waldron supplies a completely integrated Feed Control System including: the feeder-conditioner, Centri-feeder™ distributor, cone shaped die cover, feed plows and use of a 3-roll design.

This controlled feeding permits maximum production rates without fear of plug-ups, uniform wear across the die face (longer die life and freedom from concentrated stress that breaks dies). It all adds up to the lowest die cost per ton of feed produced!

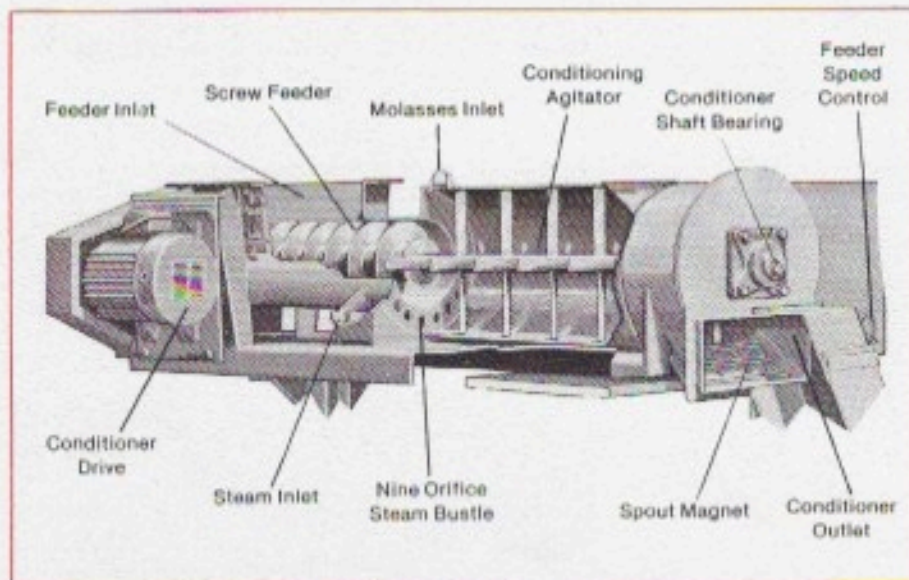

## Optimum Mash Conditioning ... Uniform Feeding

Sprout-Waldron's proven in-line feeder-conditioner concept is used on the Model 26-300 to provide complete conditioning; lower overall height. The in-line design prevents steam from escaping from the conditioner into the feeder, thus preventing steam condensation and feed build-up in the spouts and supply bins.

Adjustable paddles on the conditioner agitator combine with the variable speed feeder to assure uniform delivery of the varying formulations to the feed spout ... free of surges and slugs that cause erratic pellet mill operation.

Features of this feeder-conditioner include:

- Stainless construction to prevent corrosion.
- Complete seal for clean operation.
- Quick-opening door exposing the entire conditioner interior. This provides a practical access for complete clean-out to minimize contamination.
- Magnet for protection from tramp metal easy to reach at front of mill. Encourages frequent cleaning.
- Dial Thermometer.
- Variable speed drive for the 12" feed screw ... with controls at convenient height at front.
- Constant speed drive for the conditioner.
- 18 x 56 conditioning chamber.

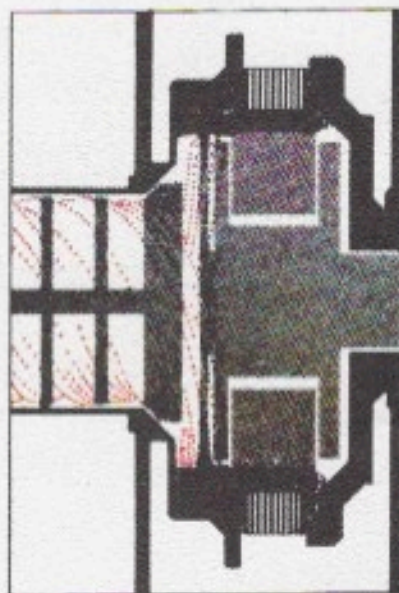

## Centri-feeder® Distributor Develops "Moving Feed Cylinder"

Feeding systems that count on gravity to move mash into the die cavity inevitably end up with the rear of the die starved or one roll assembly doing all the work. Mash flow *must* be controlled ... it just won't go there on its own!

Not just a stuffing screw, but a true centrifugal feeding mechanism, the unique Centri-feeder distributor developed by Sprout-Waldron provides controlled feeding and efficient distribution to each roll. It significantly reduces plug-up tendencies by minimizing uneven feed to the rolls and material hangup in the feed spout.

The Centri-feeder is a high-speed screw and paddle-type conveyor with a cone-shaped discharge. It receives

material from the conditioner, accelerates it, and conveys it to the cone-shaped discharge where it is discharged around the complete 360° inside face of the die.

The cone-shaped die cover continues control of the material and drives it toward the rear of the die for better distribution across the die face.

The Centri-feeder assembly, powered by a 5 hp motor, is bolted to the main mill door.

## Feed Plows Give Mash "Blanket" Precise Laydown

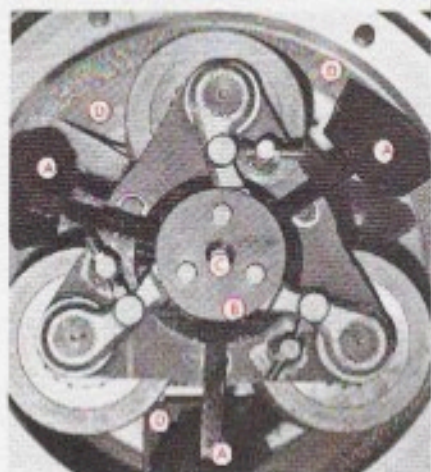

Adjustable feed plows (A) are mounted on common base (B) for movement as unit. They are secured by single bolt (C). Scrapers (D) keep housing clear of build-up and assist feed plows in directing mash across the die face.

Sprout-Waldron uses three adjustable plows . . . not just a single fixed unit. The three plows divide the mash into three equal portions . . . and place it ahead of each roll.

These plows can also be rotated 24° to control distribution of mash from front to rear of die. Products with varying bulk density and fibre content flow quite differently . . . hence you need an adjustable feeding system. Light fluffy materials have to be pushed to the back . . . heavy, easy-flowing materials have to be restrained.

Uniform loading of the pellet mill is critical in achieving the maximum potential production. It also makes for smooth operation, even die wear and leveling of the power demand.

Superior feed control reduces or eliminates concentrated loading on one or two rolls . . . reducing uneven wear, bearing failures and even die breakage.

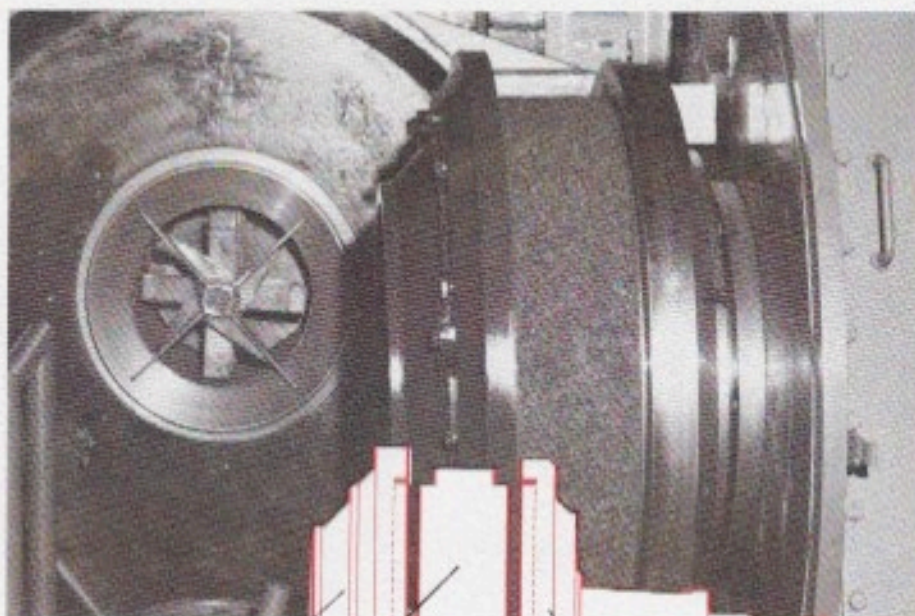

Stiffner Ring  
Die  
Die Housing  
Replaceable Wear Rings

## Rugged Support Method Extends Die Life

### Die Housing

The Sprout-Waldron die mounting method provides maximum support strength with minimum wear between die and housing. This drastically reduces excess clearances that permit die slippage with consequent fatigue loading and ultimate die breakage long before the die has worn out.

The 26-300 die housing is constructed of heat treated alloy steel . . . into which a replaceable hardened wear ring is installed. The die is press fit inside the die housing, and is bolted securely in place. This attachment is much more positive than other pellet mills and is much less subject to wear than tapered clamping mechanisms.

Should the die become loose in the 26-300, it is normally only necessary to replace the low cost wear ring, not the entire housing.

### Stiffner Ring

A thick stiffner ring is mounted on the outside of the die using twelve high tensile bolts. Now you have support at both front and rear of the die . . . to reduce die stress as much as 75% that of dies supported at the back only! This reduces die flexure and appreciably prolongs die life. No other pellet mill offers this important feature.

The stiffener ring keeps the die from distorting thus the die remains parallel to the roll face at all times so that all rows of die holes pellet evenly.

Adequate die support is very important because of extreme pressures which act on the die during pelleting. The portion of the stiffener ring which fits into the die contains a hardened wear ring similar in arrangement to that on the die housing.

The cone shaped die cover is quickly removed from the front of the stiffner ring to give quick access to the die cavity for roll adjustment or clean out.

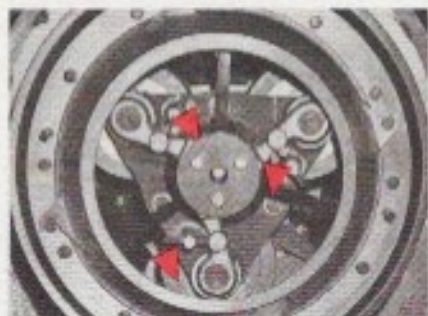

Adjusting screws provide positive setting of each roll. Adjustment is simple procedure – from front of mill.

### Three-Roll Assembly

To fully utilize the increased die working area and the higher horsepower, three 10" diameter rolls are provided. They increase capacity potential and produce a more stable operation.

Positive individual roll adjustment can be easily made from the front of the mill. It is not necessary to remove the die cover. Adjusting screws provide a quick, positive roll setting.

Each roll is greased through the main shaft while the pellet mill is running.

### Roll Shells Give Extended Life

Ruftex Shell



Sprout-Waldron's Ruftex™ roll shell, with tungsten carbide inlay, is the longest wearing (up to three times that of average ordinary indented or corrugated unit) roll shell in the industry today.

The Ruftex shell is designed to deliver maximum traction, thus substantially increasing capacity and die life. This shell frequently outlives two dies.

An indented shell is also offered. It is produced by drilling holes in alloy steel heat treated forgings with a high hardness factor. The special arrangement of these holes with indentations reduces side slippage of the feed which is common with corrugated shells.

## Sprout-Waldron Dies Keep Production Costs Low



Dies are 26" inside diameter. Die at left is 8 1/4" wide, largest commercially available in industry, and has 490 square inches of working surface. At right is 6" wide die with 348 square inches of working surface.

Proper die design and selection of the right die for the application are major considerations for high-tonnage, quality pellet production.

For those easy-to-pellet feedstuffs, Sprout-Waldron has developed an 8 1/4" wide die... one of the largest in the industry... a factor in higher production of quality pellets.

A 6" wide die is available for those hard-to-pellet feeds and bulky ingredients.

All dies used on the Model 26-300 have an inside diameter of 26". They are designed to match the horsepower and three rolls for high capacity, efficiency and stable operation. A variety of thicknesses are available for both widths to match varying formulations.

Stainless or carbon steel dies are available in a variety of perforation sizes. All dies are heat-treated, checked for hardness, core structure and composition in our Metallurgical Laboratory. Dies are then ground to close tolerances for proper fits.

Sprout-Waldron dies, noted for their low per ton pelleting cost and long life, are run-in on a regular pellet mill to polish the holes before shipment and are ready for immediate high production. This is a big advantage over dies which must be polished in the field before full production can be realized.

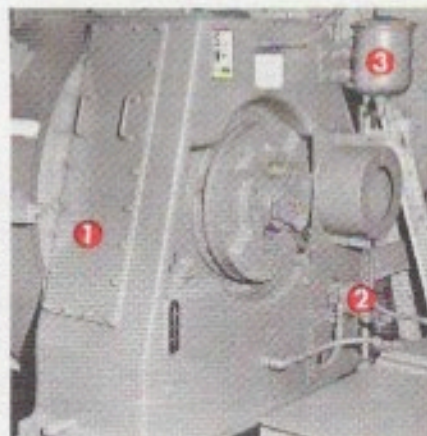

### Gear Casing Rugged Cast Ductile Iron

Sprout-Waldron uses a single gear reduction within the pellet mill. This reduces the number of moving parts, minimizing maintenance cost. The main bearing and main oil seal are instantly accessible after the cartridge is removed.

Inspection panels (1) are provided for the gear drive mechanism. The main gear can be easily removed from the side of the gear casing without removing the feeder-conditioner.

### Positive Lubrication

An external-mounted oil pump (2) forces the oil through a filter (3) and cooler to provide cool, filtered oil to all the moving parts. The system also includes temperature control, level indicator and an oil flow safety switch.

A manual greasing system is provided for the main shaft bearing and roll assemblies. The pellet mill can be lubricated from the rear while it is running. Grease access to these assemblies is provided through internal drillings in the main shaft. This provides positive lubrication to the bearings without need of external lubrication tubes that are prone to damage.



With cartridge removed from pellet mill housing, the main bearing and oil seal are easily accessible. Cylindrical bearings are mounted in straight inner races at both main center bearing and the pinion shaft (left) to simplify servicing. Labyrinth seals are used on both the pinion shaft and rear main bearing to overcome leakage synonymous with contact-type seals.

## Pelleting Cartridge Opens New Vistas for Production Scheduling

... makes possible  
10 minute die changes!

More and more, competitive forces, least-cost formulating and demanding customer specifications are forcing frequent die changes. They are tough on scheduling and expensive.

There's a way out!

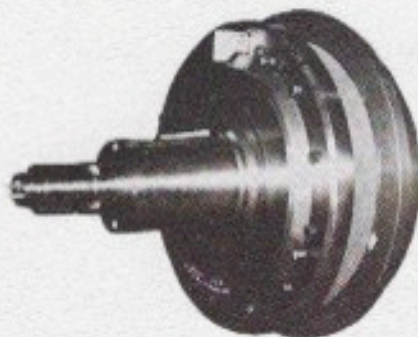

A rapid-change pelleting cartridge (die housing, die, die cover, rolls, main shaft, etc.) makes short production runs in the Model 26-300 economically feasible. With this cartridge, it is possible to change dies in ten minutes. In addition, the cartridge concept eliminates the mis-matching of dies and rolls that occurs with die changes.

With a 26-300 spare cartridge on a nearby service stand, an operator has a cool and readily accessible assembly in which to replace rolls and shells or perform any maintenance needed... without interrupting production runs.

The cartridge is held securely in place by four retaining bolts. Removal of the cartridge from the mill is a simple job. By backing off the retaining bolts, the cartridge is ejected from the pellet mill. Reversing the same bolts draws the cartridge back into the mill.

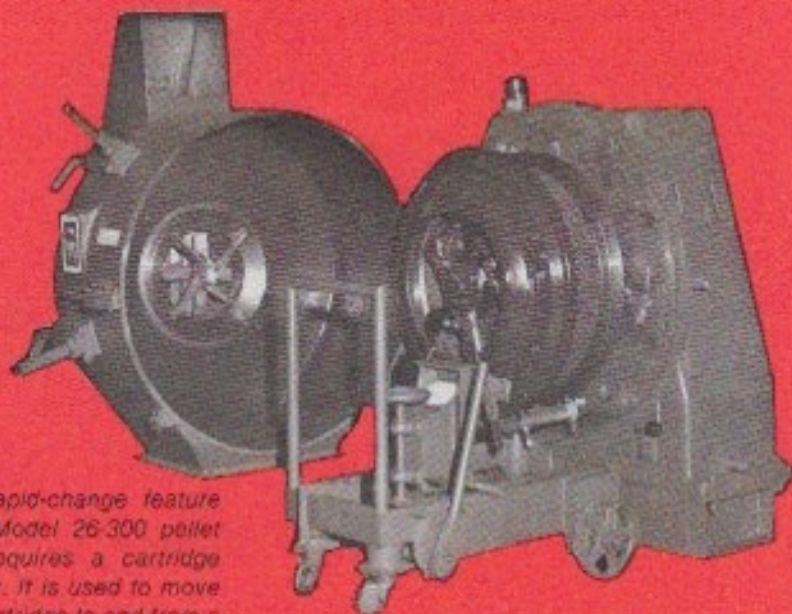

The rapid-change feature of a Model 26-300 pellet mill requires a cartridge carrier. It is used to move the cartridge to and from a storage-service stand.

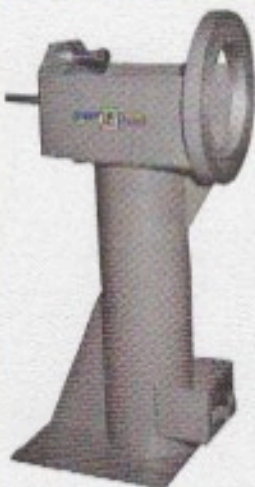

### Storage- Service Stand

A sturdy stationary stand is used for storage and servicing of a spare pelleting cartridge. This minimizes interruptions in pelleting operations because it enables the operator to replace dies and rolls and perform other maintenance at his convenience.

### Dependability Starts with Massive Main Shaft

Ultimately, the stresses and shock of pelleting are transmitted to the main shaft.

Sprout-Waldron uses a massive 5½" diameter main shaft (heaviest in the industry) to absorb the punishing duty encountered in many applications. The shaft is an integral casting, machined to exacting tolerances and heat treated for superior wear resistance and strength. This maintains long-term accuracy of bearing fits and results in extended bearing life. Cylindrical roll

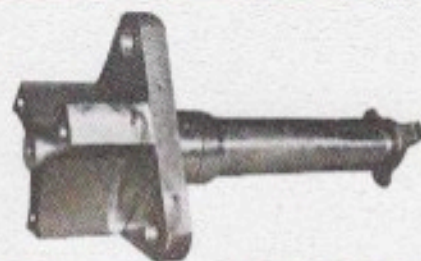

bearing assembly maintains the proper mainshaft/die housing relationship yet permits quick removal of the shaft for maintenance. There is no need for bearing adjustment.

### Sprout-Waldron Concept Unearths Hidden Profits

... N/W Die Pair

Now, and for the first time, you can realize the full potential of a quick-change cartridge and 300 hp!

Utilizing two cartridges... a wide die on one and a standard width on the second, you can get flexibility to match working surface, die thickness and applied hp to all your formulas.

No longer do you have to compromise your total pellet mill capacity by the restrictions of a single die width... or thickness. If you standardize on a 6" wide die because of the high stresses of some hard-to-run formulas... you're losing valuable production on the easy pelleting runs. But, you don't have to!

With a Model 26N/W-300, you quickly wheel in a wide die cartridge for the easy formulas... and get full benefit of your pellet mill's available horsepower!

## Single Speed Specifications

Pellet Mill Model	HP <sub>1</sub>	Feeder-Conditioner	Conditioner HP <sub>2</sub>	Feeder HP	Approximate Weights <sub>3</sub>	
					Mill	Feeder-Conditioner
26-300 SS	300	18 × 56	7½ to 15	1½	11,000	2,130
26W-300 SS	300	18 × 56	7½ to 15	1½	11,600	2,130

## Dual Speed Specifications

26-300 DS	300	18 × 56	7½ to 15	1½	12,400	2,130
26W-300 DS	300	18 × 56	7½ to 15	1½	13,000	2,130

NOTES: 1. All motors at 1800 rpm. 200 hp also can be used.

2. Dependent on application.

3. Includes motors and drives

### Models 26-/26W-300 Single Speed

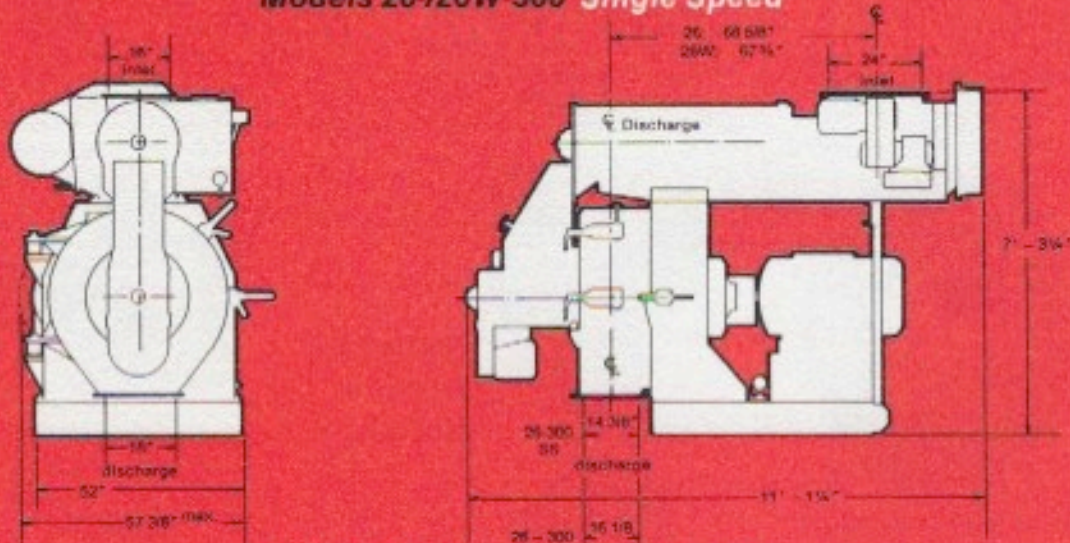

### Models 26-/26W-300 Dual Speed

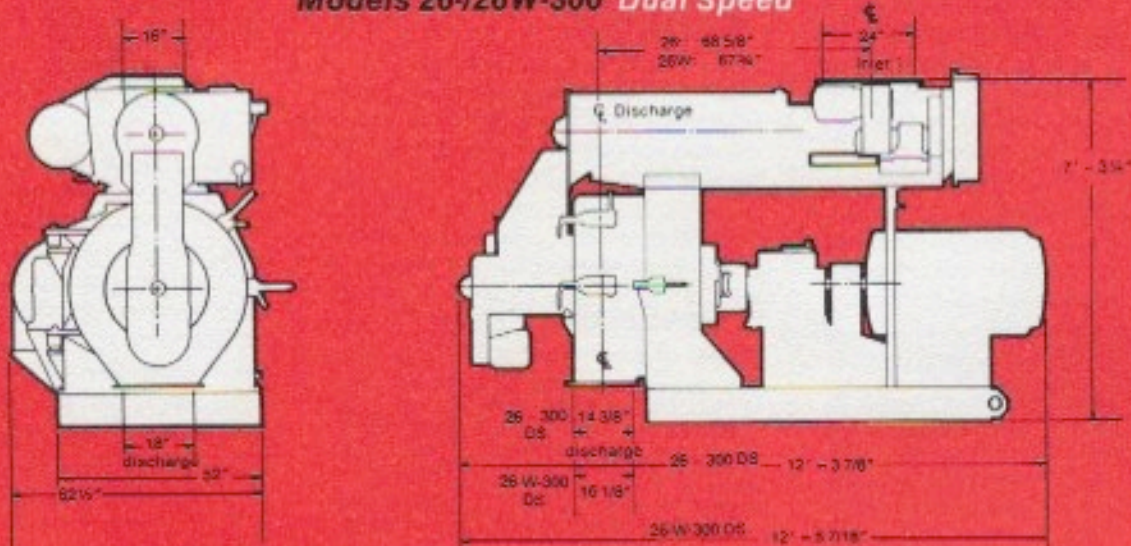

DIMENSIONS: Approximate. For installation, request certified print.

Sprout-Waldron  
Metal Products Division  
Koppers Company, Inc.  
Muncy, PA 17758  
Telephone 717/546-8211

**KOPPERS**  
Engineered  
Products